



megamount 2-26T2 / 2-26T

TYRE CHANGER
FOR TRUCK MOBILE
ROADSIDE SERVICE
WITH LOCKING CAPACITY
UP TO 30"

MOBILE
SERVICE

UP to
30"

LEVER
LESS

TOOL
HOLDER

CONTROL
UNIT



megamount



New Hofmann Megaplan Tyre Changer designed for mobile service on trucks and buses wheels up to 26" (megamount 2-26T) and up to 30" (megamount 2-26T2). Mounted at the rear of the vehicle, the new right-facing chuck allows to work safely at the roadside.

ALWAYS TANGENT working system: the roller and/or the leverless tool always work in an ideal position, tangent to the edge of the rim, so as not to damage both the tire and the rim itself.

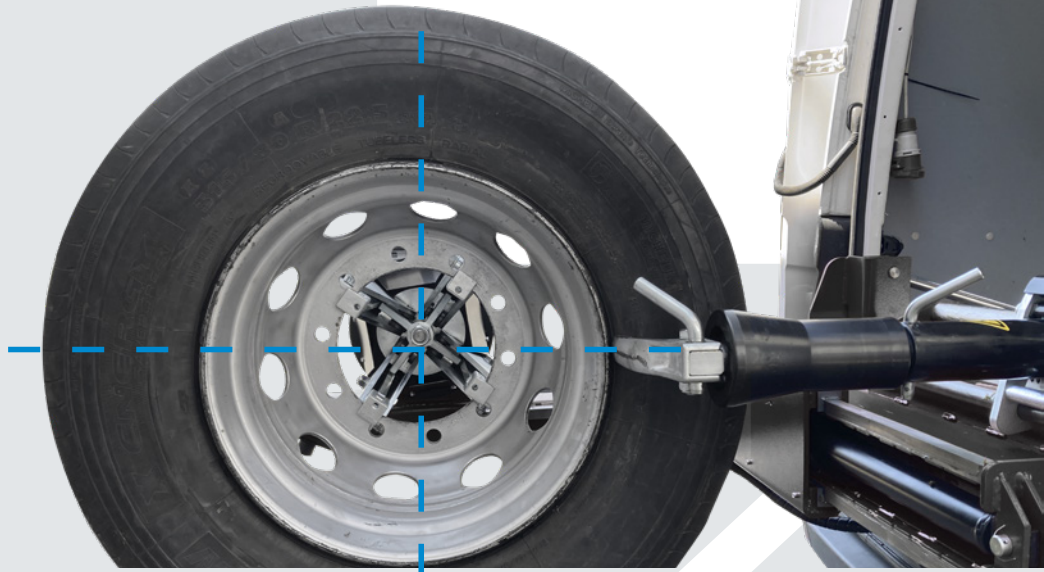

megamount 2-26T2 : model with right-hand chuck orientation

megamount 2-26T : model with left-hand chuck orientation



Standard foot support H=700 mm.

megamount

megamount 2-26T2 / 2-26T

TYRE CHANGER FOR TRUCK
MOBILE ROADSIDE SERVICE
WITH LOCKING CAPACITY UP TO 30"



Self-centering chuck

The self-centering chuck, mounted on the movable spindle arm, has 4 jaws with locking capacity from 13" to 30". The clamping points of the jaws ensure a perfect clamping of any type of rim.



Portable control unit

The machine is equipped with a low voltage portable control unit, easily movable inside the working area. The rational lay-out of control levers, buttons and pedals prevents the operator from making accidental operational errors. Available in two versions: via cable and via radio transmission.



Leverless system

It is equipped with roller, for a quick demounting/mounting procedure, or with a leverless system by means of a nail to reduce bending and tension on the heel and on the rim edge. It minimizes the physical effort of the operator.



Emergency manual pump

In case of failure of the electrical / hydraulic system, the work unit always returns to the van. Automatic motor stand-by in case of prolonged non-use to reduce energy expenditure.



Security Micro-switches

They prevent any damage to the equipment and to the van.

Standard accessories



Bead lever



Aluminum rim clamp

Optional accessories



Steel bead breaker disc



Ring protection for 22,5" alloy rim



Set of 4 plastic protections for aluminum rims with locking rotation pin



Clamp for aluminium rims



Passenger wheel kit for car wheels



Support foot extension for installation at a height greater than 70 cm

Versions on request:

Single speed version: 230V/50Hz/3ph

Single speed version: 230V/60Hz/3ph

megamount 2-26T/megamount 2-26T2:

version with data transmission via cable

megamount 2-26T R/

megamount 2-26T2 R:

version with data transmission via radio

Version with generator+compressor:

Optional power unit

(generator+compressor), as an ideal mobile workstation that allows you to work on the road with the same features and performances in your tyre service workshop.

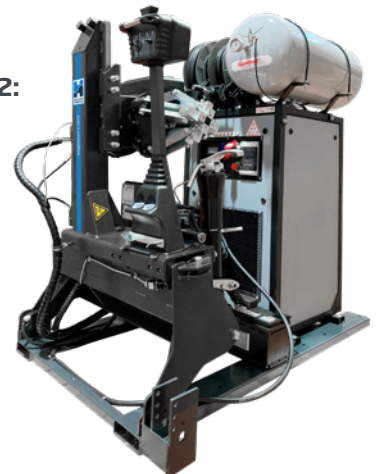

Paguro P2

Hofmann suggests the combination with Paguro P2, the space-saver handspin balancing system for truck and bus wheels

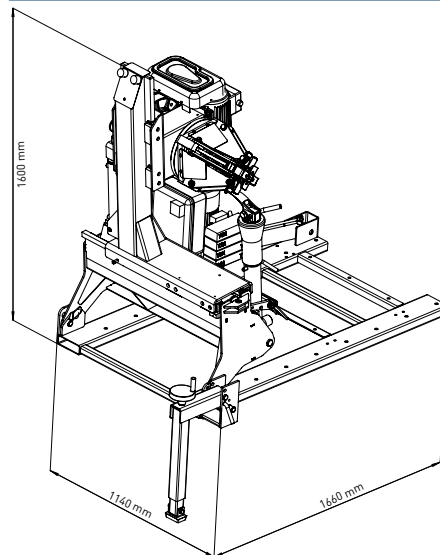
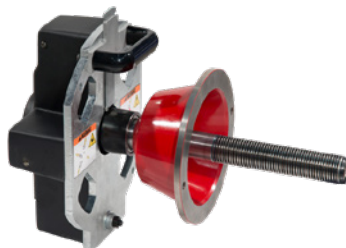

Technical Data

Internal clamping

13" - 26" (megamount 2-26-T)

Max wheel diameter

13" - 30" (megamount 2-26-T2)

1380 mm (54")

Max wheel width

930 mm (37")

Max bead-breaking power

19500N

3-Phase

kW 400V - 50Hz (1 speed)

Turntable speed

7 rpm (3ph - 1 speed)

Operating pressure

8 - 12 bar (116 - 174 psi)

Noise level

< 70 ± 3 dB (A)

Net weight

530 kg



HOFMANN MEGAPLAN GmbH

Hüttenstrasse 7 - 67550 Worms - Germany

T +49 (0)6242 913 6666

hm-mail@hofmann-megaplan.com

www.hofmann-megaplan.com