



megamount 15FS/15

SEMI-AUTOMATIC
TYRE CHANGER
WITH LOCKING
CAPACITY
UP TO 24"

HPX
S

UP to
24"



megamount 15FS

BEAD
BREAKER
UP TO 13"

DOUBLE
SPEED
— 2X —

Hofmann Megaplan tyre disassembly tool, essential but complete with all the necessary devices to allow the operator to work easily on all types of wheels. Smartly designed self-centring turntable and removable foot pedal are standard on all models.

Semi-automatic tyre changer equipped with horizontal pole with laterally adjustable flag. The vertical rod is blocked by a lever while a functional knob allows the tool to be positioned laterally with respect to the rim. Special accessories, available on request, expand the possibility of working also on wheels with rims from 3.6 to 22".



megamount 15

megamount

megamount 15FS / 15

SEMI-AUTOMATIC TYRE CHANGER
WITH LOCKING CAPACITY
UP TO 24"



UP to
24"

Locking capacity up to 24"

The sturdy square-shaped self-centring turntable has a clamping capacity from 10" to 24" and is characterized by the opposing jaw clamping system with 80 mm diameter cylinders that adapt to all types of rims. The shape of the turnplate is designed so as to ease the bead-breaking of the second bead.



BEAD
BREAKER
UP TO 13"

Bead breaker up to 13"

Ergonomic bead breaker system which enables to operate on large wheels up to 13" width.

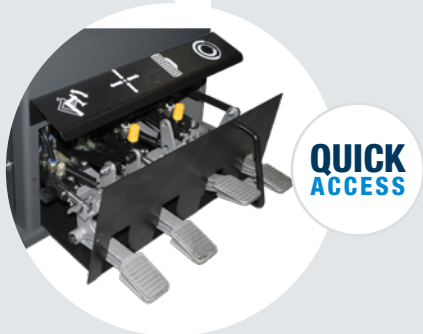

QUICK
ACCESS

Easy access

Removable pedal unit, to facilitate technical assistance, sturdy reducer, standard inflation pressure limiter in compliance with CE standards and already prepared for connection of the inflating gun.

Double rotation system

Motor with dual rotation clockwise and counterclockwise and double speed.
400V/50-60Hz/3ph motor.

DOUBLE
SPEED
— 2X —

HELPING DEVICE SYSTEM HPX-S

The *megamount15FS* is supplied with HPX-S as standard.
Useful to operate on particularly hard and large-sized Run-Flat and UHP Tyres.

HPX
S



Standard accessories



Bead lever



Set of plastic protections

Optional accessories



HPX-5 (for Megamount15)



Inflating gun



WDK lever



Run Flat clamp



Quick interchangeable mounting head system, composed by adaptors and 2 mounting heads (one in plastic and one for raised spokes)

For motorcycle wheels:



Set of 4 jaws for bike wheels with 6"-23" rim



Mounting head for scooter wheels with 8" rims



Bead breaker blade for motorcycle wheels

3-Phase motor version:: 0.8 - 1.1 kW 400V/50-60 Hz/3ph (2 speed) - 7-14 rpm

Versions on request

Single speed version: 0.75 kW 230V/50Hz/1ph - 7 rpm

Single speed version: 0.75 kW 230V/60Hz/1ph - 7 rpm

Single speed version: 0.75 kW 110V/60Hz/1ph - 7 rpm

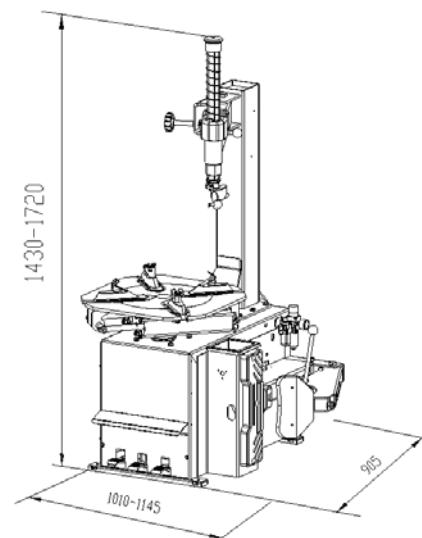

Technical data

Clamping capacity	10" - 24"
External clamping	10" - 22"
Internal clamping	12" - 24"
Max wheel diameter	1000 mm (39.5")
Max wheel width	330 mm (13")
Bead breaker force	3000 kgf
Turntable speed	7-14 rpm (7 rpm 1ph)
3-Phase motor	0.8 - 1.1 kW
Operating pressure	10 bar (145 psi)
Noise level	< 70 ± 3 dB (A)
Net weight	230 kg
Gross weight	760 x 975 x 950 mm
Packing dimensions	



HOFMANN MEGAPLAN GmbH
Hüttenstrasse 7 - 67550 Worms - Germany
T +49 (0)6242 913 6666 - hm-mail@hofmann-megaplan.com
www.hofmann-megaplan.com