

# *megamount* 351



**The ideal tyre changer for owners of commercial vehicles who change tyres personally. Time saving and user friendly**

That is self-evident for us:

- Tyre changer for trucks and busses with tubeless tyres
- Clamping range 14 - 26 inches
- Tyre width maximum 780 mm
- Tyre diameter maximum 1200 mm

For all problems the right solution:



- **CONTROL UNIT**

Simultaneous relocation of the control column and of the double act breaker arm: Control of the machine always in the field of view of the operator.

- **DOUBLE ACT BEAD BRAKE AND MOUNTING ARM**

Hydraulically driven, for a fast and economic handling. External arm with roller and special assisting tool to handle tube tyres as well.

- **REASONABLE PRICE**

A clever investment to cut the maintenance costs for your vehicles.

This comes with the machine



<b>Technical Data</b>	
Clamping Range	14"-26"
Max. wheel weight	1500 kg
Max. wheel diameter	1200 mm
Max. wheel width	780 mm
Hydraulic pump motor	1,1 kw 230/400 v-3PH
Gearbox motor	1,5 kw 230/400 v-3PH
Operating pressure	0 - 130 bar
Bead breaker force inside-outside	1865 kg
Noise level in working condition	< 70 db
Net weight	400 kg

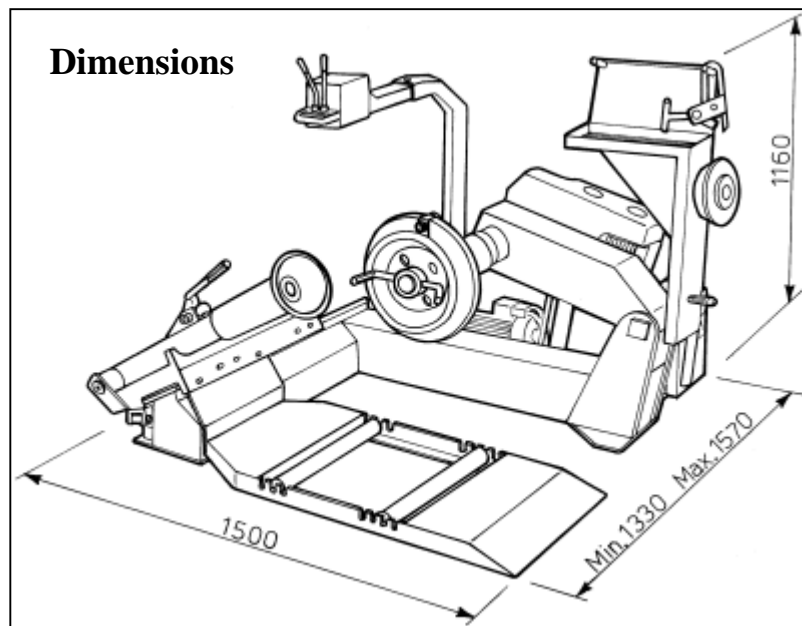

HOFMANN MEGAPLAN GMBH  
Hauptstraße 59  
A-5302 Henndorf • Austria  
Tel: +43-6214-646612 Fax - 646622  
[company@hofmann-megaplan.com](mailto:company@hofmann-megaplan.com)  
[www.hofmann-megaplan.com](http://www.hofmann-megaplan.com)